



SUB CONTRACTOR:
 T & C QATAR L.L.C. - C.R. 35109
 P.O. Box: 2329 DOHA, QATAR
 TEL: (+974) 4421 833 / 4930 614
 FAX: (+974) 4410 553 / 4930 614



CONSULTANT:
 المكتب العربي للهندسة
 ARAB ENGINEERING BUREAU
 تأسس 1974 م - رقم الترخيص 1118
 Telephone: +974 4477 991 Fax: +974 4477 988 P.O. Box 148 Doha Qatar
 Email: ae@ae-qatar.com Web: www.aeb-qatar.com



DESIGNER:
 GHD
 GHD
 P.O. Box 14332 Doha Qatar
 T: +974 4433391 F: +974 4446927
 E: doham@ghd.com.au www.ghd.com.au



MAIN CONTRACTOR:
 AL MADAR CONTRACTING
 P.O. Box: 2329 DOHA, QATAR
 TEL: (+974) 4675405 - 4674466
 FAX: (+974) 4671333 - C.R. : 15061
 WEB SITE: www.almadar-group.com
 Email: conteng@almadar-group.com



OWNER:
 ALI ABDUL REDA MASHHADI

PROJECT:
 AL NOOR OFFICE TOWER AT NEW DOHA
 2B+G+F+22 FLOORS

DRAWING TITLE:
 GROUND FLOOR
 HVAC & CHILLED WATER

DRAWING REFERENCE:
 TC01MIG00050 - GROUND FLOOR FLOOR HVAC
 TC01M3G00066 - GROUND FLOOR FLOOR CHILLED WATER

DX-SPLIT UNIT SCHEDULE

REF. NO.	LOCATION	TYPE	REVERSE I	CAPACITY	POWER	WARRANTY	WARRANTY	WARRANTY
SD-01	ME-01	WALL MOUNTED	1.5	1.5	1.5	1.5	1.5	1.5
SD-02	ME-02	WALL MOUNTED	1.5	1.5	1.5	1.5	1.5	1.5
SD-03	ME-03	WALL MOUNTED	1.5	1.5	1.5	1.5	1.5	1.5
SD-04	ME-04	WALL MOUNTED	1.5	1.5	1.5	1.5	1.5	1.5

EXHAUST GRILLE:

REF. NO.	SIZE (MM)	AIR QTY (M ³ /H)	TYPE	FINISH/COLOR
EG-01	300x300	300	WALL MOUNTED	WALL MOUNTED
EG-02	300x300	300	WALL MOUNTED	WALL MOUNTED

SCH. OF SUPPLY AIR DIFFUSERS

REF. NO.	SIZE (MM)	AIR QTY (M ³ /H)	TYPE	FINISH/COLOR
SD-01	300x300	300	WALL MOUNTED	WALL MOUNTED
SD-02	300x300	300	WALL MOUNTED	WALL MOUNTED

RETURN AIR DIFFUSER

REF. NO.	SIZE (MM)	AIR QTY (M ³ /H)	TYPE	FINISH/COLOR
RD-01	300x300	300	WALL MOUNTED	WALL MOUNTED
RD-02	300x300	300	WALL MOUNTED	WALL MOUNTED

SLOT LINEAR DIFFUSER

REF. NO.	SIZE (MM)	AIR QTY (M ³ /H)	TYPE	FINISH/COLOR
SLD-01	300x300	300	WALL MOUNTED	WALL MOUNTED
SLD-02	300x300	300	WALL MOUNTED	WALL MOUNTED

SCH. OF RETURN AND DUMMY LINEAR DIFFUSERS

REF. NO.	SIZE (MM)	AIR QTY (M ³ /H)	TYPE	FINISH/COLOR
RLD-01	300x300	300	WALL MOUNTED	WALL MOUNTED
RLD-02	300x300	300	WALL MOUNTED	WALL MOUNTED

SLOT LINEAR DIFFUSER

REF. NO.	SIZE (MM)	AIR QTY (M ³ /H)	TYPE	FINISH/COLOR
SLD-01	300x300	300	WALL MOUNTED	WALL MOUNTED
SLD-02	300x300	300	WALL MOUNTED	WALL MOUNTED

SUPPLY AIR REGISTER

REF. NO.	SIZE (MM)	AIR QTY (M ³ /H)	TYPE	FINISH/COLOR
SAR-01	300x300	300	WALL MOUNTED	WALL MOUNTED
SAR-02	300x300	300	WALL MOUNTED	WALL MOUNTED

SCH. OF RETURN GRILLE

REF. NO.	SIZE (MM)	AIR QTY (M ³ /H)	TYPE	FINISH/COLOR
RG-01	300x300	300	WALL MOUNTED	WALL MOUNTED
RG-02	300x300	300	WALL MOUNTED	WALL MOUNTED

FAN SCHEDULE

FAN DESCRIPTION	SCHEMATIC AREA	LOCATION	AIR FLOW (L/S)	EXH. PRESSURE (Pa)	EXH. TEMP. (°C)	EXH. HUMIDITY (%)	EXH. DENSITY (kg/m ³)	EXH. VOLUME (m ³ /s)	EXH. MASS (kg/s)	EXH. ENTHALPY (kJ/kg)	EXH. ENTHALPY (kJ/s)	EXH. ENTHALPY (kW)	EXH. ENTHALPY (kW)	EXH. ENTHALPY (kW)	EXH. ENTHALPY (kW)	EXH. ENTHALPY (kW)	EXH. ENTHALPY (kW)	EXH. ENTHALPY (kW)	EXH. ENTHALPY (kW)	
ME-01	ME-01	ME-01	1.5	1.5	1.5	1.5	1.5	1.5	1.5	1.5	1.5	1.5	1.5	1.5	1.5	1.5	1.5	1.5	1.5	1.5

AIR HANDLING UNIT SCHEDULE

REF. NO.	LOCATION	TYPE	SIZE (MM)	AIR QTY (M ³ /H)	TYPE	FINISH/COLOR
AHU-01	ME-01	WALL MOUNTED	300x300	300	WALL MOUNTED	WALL MOUNTED
AHU-02	ME-02	WALL MOUNTED	300x300	300	WALL MOUNTED	WALL MOUNTED

FAN COIL UNIT

REF. NO.	LOCATION	TYPE	SIZE (MM)	AIR QTY (M ³ /H)	TYPE	FINISH/COLOR
FCU-01	ME-01	WALL MOUNTED	300x300	300	WALL MOUNTED	WALL MOUNTED
FCU-02	ME-02	WALL MOUNTED	300x300	300	WALL MOUNTED	WALL MOUNTED

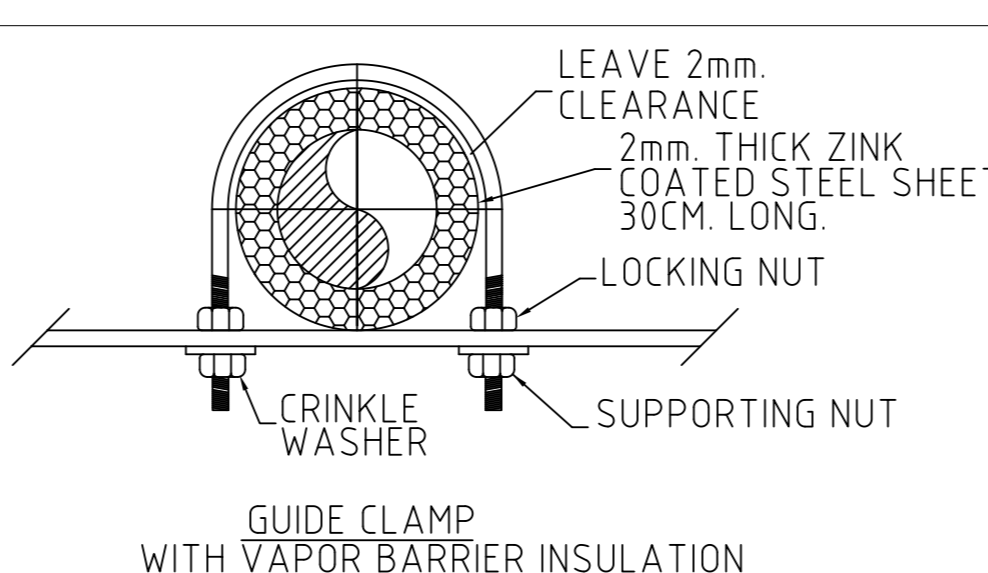
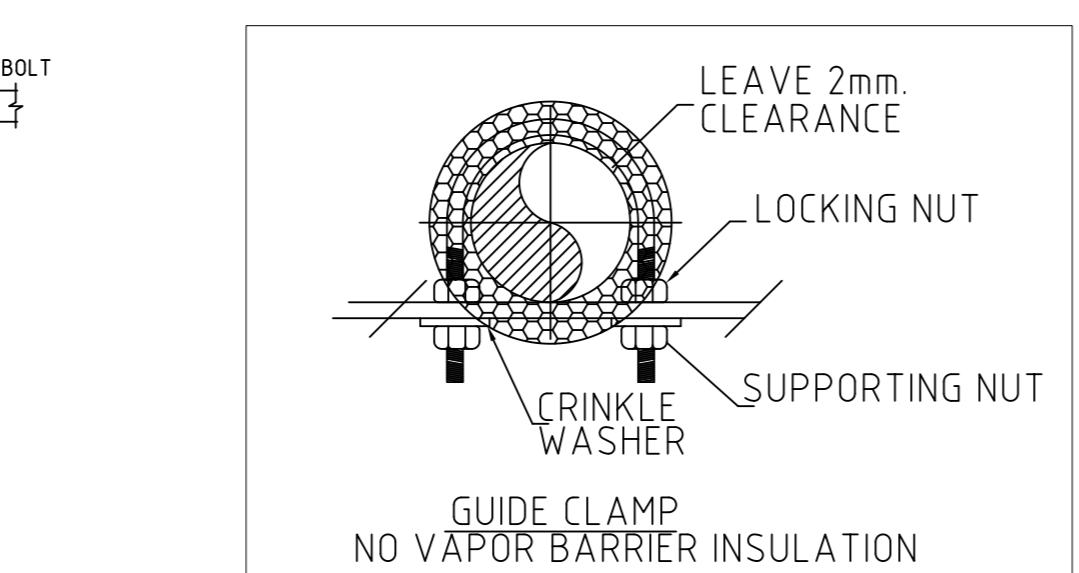
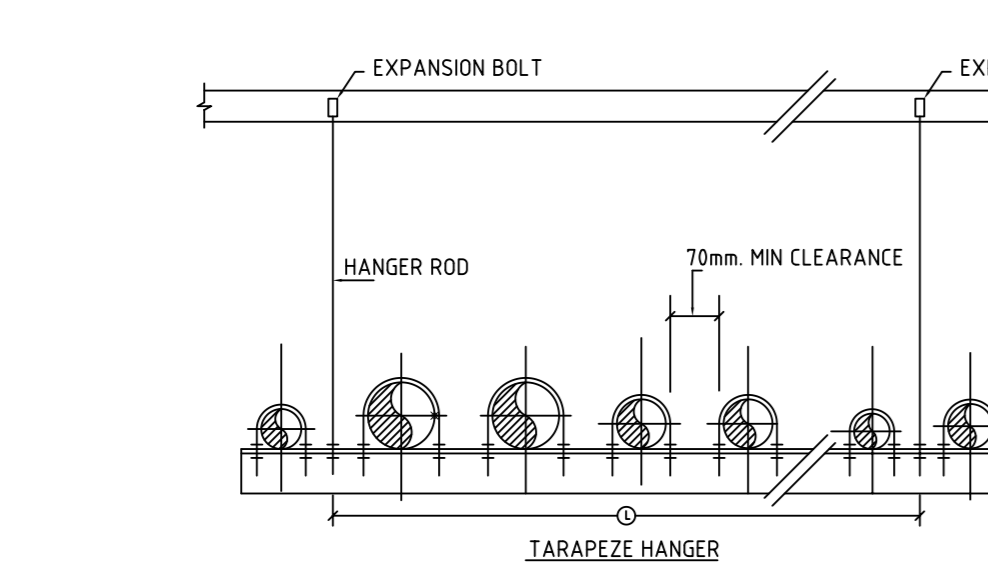
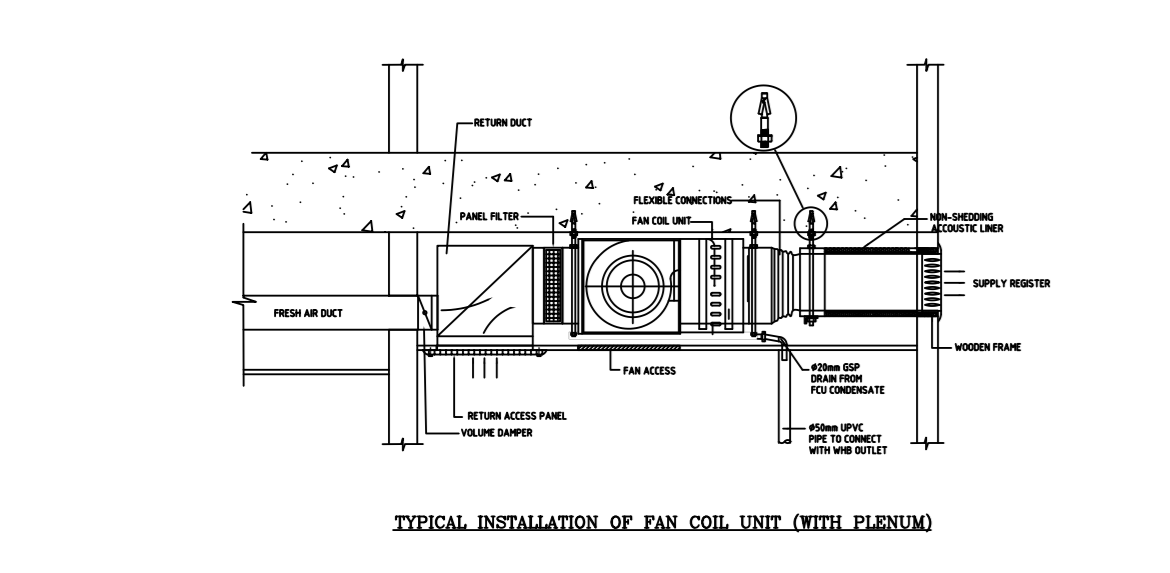

	FLEXIBLE CONNECTION 200
	VOLUME CONTROL DUMPER
	SUPPLY DIFFUSER
	RETURN DIFFUSER
	EXHAUST GRILLE
	LINEAR SLOT DIFFUSER SUPPLY & RETURN
	SUPPLY GRILL
	RETURN GRILL
	DUCT RISER
	INDOOR UNIT

FAD	FRESH AIR DUCT
EAD	EXHAUST AIR DUCT
AHU	AIR HANDLING UNIT
FCU	FAN COIL UNIT
VD	VOLUME DUMPER
CHWS	CHILLED WATER SUPPLY
CHWR	CHILLED WATER RETURN
RLD	RETURN LINEAR DIFFUSOR
SLD	SUPPLY LINEAR DIFFUSOR
DLD	DUCT LINEAR DIFFUSOR
IL	INVERT LEVEL
LEN	LENGTH
ID	INDOOR UNIT
EG	EXHAUST GRILL
EF	EXHAUST FAN
H / L	HIGH LEVEL
F / A	FROM ABOVE
T / B	TO BELOW
SG	SUPPLY GRILL
RG	RETURN GRILL

DRAWN BY	D. PASQUINELLI		
CHECKED BY	M. ALAA		
APPROVED BY	M. MOHAMUD		
DATE	05.07.07		
SCALE	1:100	SIZE	AO
REVISION	0		
DATE	05.07.07		
DRAWING NO.	TC01M3G00066		
SHEET	1 OF 2		